

CHUROD ELECTRONICS



**IEC60079-0/15 compliant
relays (explosion-proof)
2023**

FEATURES

- Outline dimension (18.2mm×10.2mm×14.9mm)
- 1 Form A (SPST) contact arrangement
- Designed to meet cULus,TUV,CQC requirements
- 4,000VAC dielectric strength between coil and contact
- Sensitive and standard coils available
- RoHS compliance
- REACH SvHC compliance
- Halogen-Free type available Glow
- Glow wire type

APPLICATION

Industrial Control Appliances

COIL PARAMETER

Coil voltage	3-48VDC	
Coil power	A1-LA/IA	200mW
	A1-DA/HA	450mW

COIL DATA @23°C

A1-LA/IA/IA2/IA2F(200mW). Sensitive				
Nominal coil voltage (VDC)	Nominal Current (mA)	Coil Resistance (Ω)±10%	Operate Voltage (VDC Max.)	Release Voltage (VDC Min.)
3	66.7	45	2.25	0.15
5	40.0	125	3.75	0.25
6	33.3	180	4.50	0.30
9	22.5	400	6.75	0.45
12	16.7	720	9.00	0.60
18	11.1	1,620	13.50	0.90
24	8.6	2,880	18.00	1.20

A1-DA/HA/HA2/HA2F(450mW). Standard				
Nominal coil voltage (VDC)	Nominal Current (mA)	Coil Resistance (Ω)±10%	Operate Voltage (VDC Max.)	Release Voltage (VDC Min.)
3	150.0	20	2.25	0.15
5	90.9	55	3.75	0.25
6	75.0	80	4.50	0.30
9	50.0	180	6.75	0.45
12	37.5	320	9.00	0.60
18	25.0	720	15.5	0.90
24	18.0	1,280	18.00	1.20
48	9.4	5,100	36.00	2.40



File NO. E341422



File NO. R50174892



File NO. CQC10002043606

CONTACT DATA

Contact arrangement	1 Form A (SPST)	
Contact material	Ag Alloy	
Initial contact resistance	100mΩ max.@6VDC,1A	
Max. switching voltage	250VAC/30VDC	
Max. switching current	3A(LA)/5A(DA)/8A(IA)/10A(HA)	
Max. switching power	750VA/90W(LA)	1250VA/150W(DA)
	2000VA/240W(IA)	2500VA/300W(HA)
Contact rating (Resistive Load)	A1-LA:	3A @ 250VAC
		3A @ 30VDC
	A1-DA:	5A @ 250VAC
		5A @ 30VDC
	A1-IA/IA2:	8A @ 250VAC
		8A @ 30VDC
A1-HA/HA2:	10A @ 250VAC	
	10A @ 30VDC	
Mechanical endurance	10,000,000 ops Min.(no load)	
Electrical endurance	100,000 ops Min(rated load)	
Minimum load (reference value)	100mA@5VDC	

CHARACTERISTICS

Operate voltage	75% of nominal voltage or less	
Release voltage	5% of nominal voltage or more	
Operate time (At nominal voltage)	A1-LA/IA/IA2/IA2F	15ms max.
	A1-DA/HA/HA2/HA2F	10ms max.
Release time(At nominal voltage)	4ms max.	
Insulation resistance	1,000 MΩ min. (at 500 VDC)	
Dielectric strength	Between coil and contact	4,000 VAC, 50/60 Hz for 1 min
	Between open contacts	1,000 VAC, 50/60 Hz for 1 min
Surge voltage between coil and contacts	10,000V(1.2/50μs)	
Vibration resistance	Destruction	10 to 55 Hz, 1.5mm double amplitude
	Malfunction	10 to 55 Hz, 1.5mm double amplitude
Shock resistance	Destruction	1,000 m/s ² (100G approximately)
	Malfunction	100 m/s ² (10G approximately)
Ambient temperature	Operating: -30~+85°C or 105°C(H) (without icing or condensation)	
Ambient humidity	Operating: 20% to 85% RH	
Terminal	PCB terminals	
Enclosure (94V-0 Flammability Ratings)	V: Vented(Flux-tight, RTII)	
	S: Sealed(Wash-tight, RTIII)	
Weight	Approx. 6g	

ORDERING INFORMATION

	A1	-V	-1	12	H	A	2	F	,000
1.Product Family									
2.Enclosure									
V=Vented(Flux-tight, RTII) S=Sealed(Wash-tight, RTIII)									
3.Number of Poles									
1=1 pole									
4.Rated Coil Voltage									
03,05,06,09,12,18,24,48VDC									
5.Coil Power									
L&I =Sensitive(200mW) D&H =Standard(450mW)									
6.Contact Arrangement									
A = Form A(SPST)									
7.Contact Material									
Nil & 2=AgSnO ₂									
8.Insulation System									
Blank & F = Class(155°C)									
9.Additional numbers and /or letters									
000-999, AAA-ZZZ, aaa-zzz or blank, which does not represent electrical changes, only for specific customer requirements									

OUTLINE DIMENSION

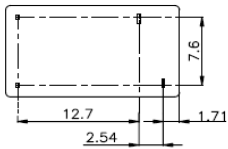
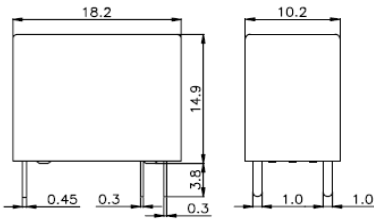

WIRING DIAGRAMS (BOTTOM VIEWS)

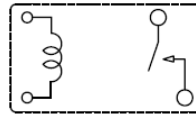

PC BOARD LAYOUTS (BOTTOM VIEWS)

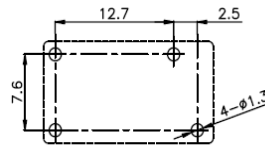

Remarks:

- The reference tolerance in outline dimension:
 - outline dimension ≤ 1 mm, reference tolerance is ± 0.2 mm;
 - outline dimension > 1 mm and ≤ 5 mm, reference tolerance is ± 0.3 mm;
 - outline dimension > 5 mm, reference tolerance is ± 0.5 mm.
- The reference tolerance for PC Board layout is ± 0.1 mm.

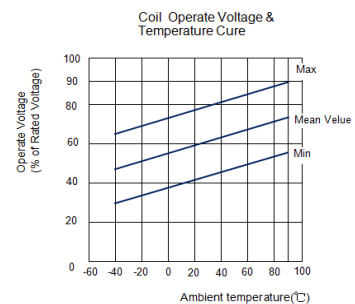
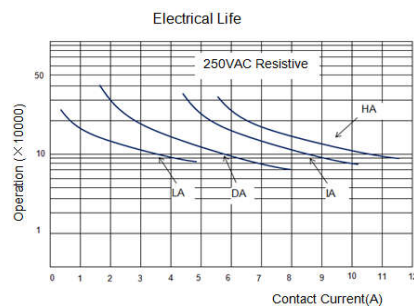
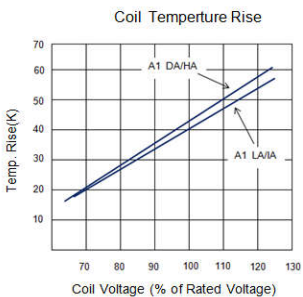

1.BOX

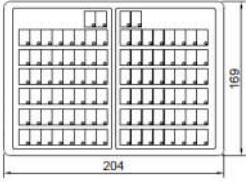

100 pcs inside a box
1000pcs inside a carton

2.TUBE

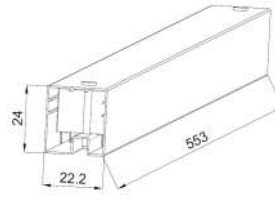

50 pcs inside a tube
2000 pcs inside a carton

Disclaimer:

The specification is for reference only,if you need more detail information,please contact Churod. We could not evaluate all the performance and all parameters for every possible application.And the user should be in a right position to choose the suitable product for their own application.If there is any new need,please contact Churod for the technical service.

[Http://www.churod.com](http://www.churod.com)

2020 Rev.00 Churod Electronics Co., Ltd.

FEATURES

- Outline dimension (20.0mm×10.0mm×15.2mm)
- 1 Form A (SPST) or 1 Form C (SPDT)contact arrangement
- Designed to meet cULus,TUV,CQC requirements
- 4,000VAC dielectric strenght between coil and contact
- Sensitive and standard coils available
- RoHS compliance
- REACH SvHC compliance
- Halogen-Free type available Glow
- Glow wire type



File NO. E341422



File NO. R50174892



File NO. CQC10002043606

APPLICATION

Air Conditioner, Washing Machine, Microwave Oven,
Power Meter, Industrial Control

COIL PARAMETER

Coil voltage	3-48VDC	
Coil power	Sensitive	200mW
	Standard	400mW

COIL DATA@23°C

A2-LA2/LC2(200mW).Sensitive				
Nominal coil voltage (VDC)	Nominal Current (mA)	Coil Resistance (Ω)±10%	Operate Voltage (VDC Max.)	Release Voltage (VDC Min.)
3	66.7	45	2.25	0.15
5	40.0	125	3.75	0.25
6	33.3	180	4.5	0.3
9	22.2	405	6.75	0.45
12	16.7	720	9	0.6
18	11.1	1620	13.5	0.9
24	8.3	2880	18	1.2
48	4.2	11520	36	2.4

A2-DA2/DC2(400mW).Standard				
Nominal coil voltage (VDC)	Nominal Current (mA)	Coil Resistance (Ω)±10%	Operate Voltage (VDC Max.)	Release Voltage (VDC Min.)
3	133.3	22.5	2.25	0.15
5	80.0	62.5	3.75	0.25
6	66.7	90	4.5	0.3
9	44.4	202.5	6.75	0.45
12	33.3	360	9	0.6
18	22.2	810	13.5	0.9
24	16.7	1440	18	1.2
48	8.3	5760	36	2.4

CONTACT DATA

Contact arrangement	1 Form A (SPST) / 1 Form C(SPDT)	
Contact material	Ag Alloy	
Initial contact resistance	100mΩ max.@6VDC,1A	
Max. switching voltage	277VAC/30VDC	
Max. switching current	7A(N.O)/5A(N.C)	
Max. switching power	1,939VA/150W(N.O)	
	830VA/90W(N.C)	
Contact rating (Resistive Load)	Form A	10A @ 125VAC
		5A @ 277VAC/30VDC
		H Type 7A @ 277VAC
	Form C	5A @ 277VAC/30VDC (N.O)
3A @ 277VAC/30VDC (N.C)		
H Type 7A @ 277VAC (N.O) 5A @ 277VAC (N.C)		
Mechanical endurance	10,000,000 ops Min.(no load)	
Electrical endurance	100,000 ops Min(rated load)	
Minimum load (reference value)	100mA@5VDC	

CHARACTERISTICS

Operate voltage	75% of nominal voltage or less	
Release voltage	5% of nominal voltage or more	
Operate time (At nominal voltage)	Sensitive Coil	15ms max.
	Standard Coil	10ms max.
Release time(At nominal voltage)	5ms max.	
Insulation resistance	1,000 MΩ min. (at 500 VDC)	
Dielectric strength	Between coil and contacts	4,000 VAC, 50/60 Hz for 1 min
	Between open contacts	1,000 VAC, 50/60 Hz for 1 min
Surge voltage between coil and contacts	8,000V(1.2/50μs)	
Vibration resistance	Destruction	10 to 55 Hz.,1.5mm double amplitude
	Malfunction	10 to 55 Hz.,1.5mm double amplitude
Shock resistance	Destruction	1,000 m/s2(100G approximately)
	Malfunction	100 m/s2(10G approximately)
Ambient temperature	Operating: -40~+85°C (without icing or condensation)	
Ambient humidity	Operating: 20% to 85% RH	
Terminal	PCB terminals	
Enclosure (94V-0 Flammability Ratings)	V: Vented(Flux-tight, RTII)	
	S: Sealed(Wash-tight, RTIII)	
Weight	Approx. 7g	

ORDERING INFORMATION

	A2	-V	-1	12	D	A	2	H	,000
1.Product Family									
2.Enclosure									
V=Vented(Flux-tight, RTII) S=Sealed(Wash-tight,									
3.Number of Poles									
1=1 pole									
4.Rated Coil Voltage									
03,05,06,09,12,18,24,48VDC									
5.Coil Power									
L = Sensitive(200mW) D = Standard(400mW)									
6.Contact Arrangement									
A = Form A(SPST) C = Form C(SPDT)									
7.Contact Material									
2 = AgSnO ₂									
8.Rated Current									
Blank = 5A H = 7A									
9.Additional numbers and /or letters									
000-999 , AAA-ZZZ , aaa-zzz or blank , which does not represent electrical changes, only for specific customer requirements									

OUTLINE DIMENSION

Form A

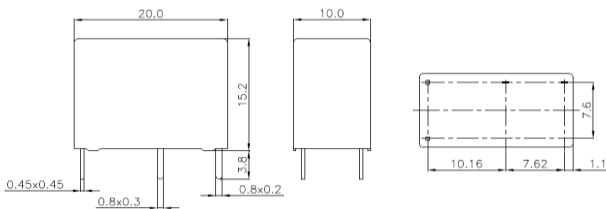

Form C

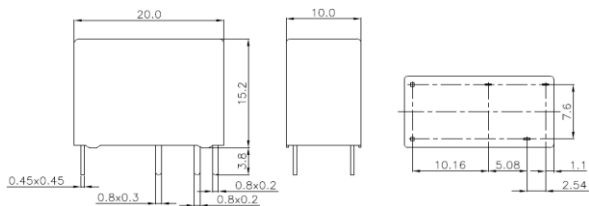

WIRING DIAGRAMS (BOTTOM VIEWS)

Form A

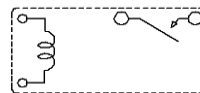

Form C

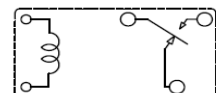

PC BOARD LAYOUTS (BOTTOM VIEWS)

Form A

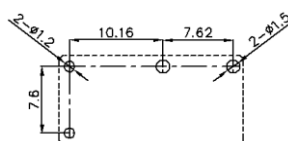

Form C

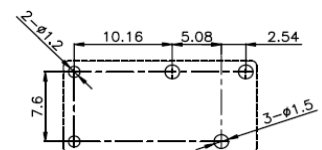

Remarks:

- The reference tolerance in outline dimension:
 - outline dimension $\leq 1\text{mm}$, reference tolerance is $\pm 0.2\text{mm}$;
 - outline dimension $> 1\text{mm}$ and $\leq 5\text{mm}$, reference tolerance is $\pm 0.3\text{mm}$;
 - outline dimension $> 5\text{mm}$, reference tolerance is $\pm 0.5\text{mm}$.
- The reference tolerance for PC Board layout is $\pm 0.1\text{mm}$.

REFERENCE DATA

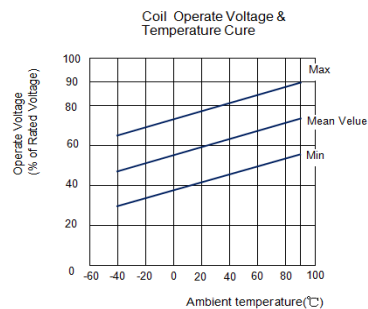
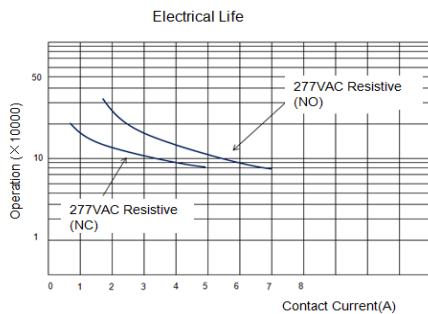
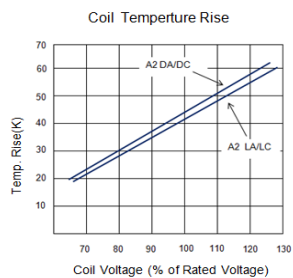

PACKAGING FIGURE

1.BOX

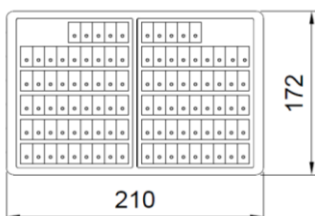

100 pcs inside a box
1000pcs inside a carton

2.TUBE

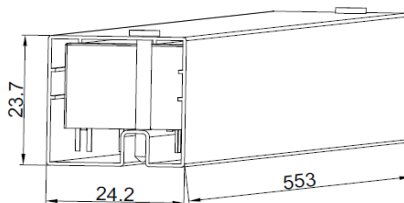

50 pcs inside a tube
2000 pcs inside a carton

Disclaimer :

The specification is for reference only,if you need more detail information,please contact Churod. We could not evaluate all the performance and all parameters for every possible application. And the user should be in a right position to choose the suitable product for their own application.If there is any new need,please contact Churod for the technical service.

[Http://www.churod.com](http://www.churod.com)

2020 Rev.02 Churod Electronics Co., Ltd.

CHM Series 5A MINIATURE POWER RELAY

FEATURES

- Outline dimension (20.4mm×7.0mm×15.0mm)
- 1 Form A (SPST) contact arrangement
- Designed to meet cULus, TUV, CQC requirements
- 4,000VAC dielectric strength between coil and contact
- Sensitive and standard coils available
- RoHS compliance
- REACH SvHC compliance
- Halogen-Free type available Glow
- Glow wire type

APPLICATION

Air Conditioner, Washing Machine, Microwave Oven, Power Meter, Industrial Control

COIL PARAMETER

Coil voltage	3-24VDC
Coil power	200mW

COIL DATA @23°C

CHM				
Nominal coil voltage (VDC)	Nominal Current (mA)	Coil Resistance (Ω) ± 10%	Operate Voltage (VDC Max.)	Release Voltage (VDC Min.)
3	66.7	45	2.25	0.15
5	40.0	125	3.75	0.25
6	33.3	180	4.50	0.30
9	22.5	400	6.75	0.45
12	16.7	720	9.00	0.60
18	11.1	1,620	13.50	0.90
24	8.6	2,880	18.00	1.20



File NO. E341422



File NO. R50174892



File NO. CQC10002043606

CONTACT DATA

Contact arrangement	1 Form A (SPST)
Contact material	Ag Alloy
Initial contact resistance	100mΩ max.@6VDC,1A
Max. switching voltage	250VAC/30VDC
Max. switching current	5A
Max. switching power	1,250VA/150W
Contact rating (Resistive Load)	5A @ 250VAC 5A @ 30VDC
Mechanical endurance	10,000,000 ops Min.(no load)
Electrical endurance	100,000 ops Min(rated load)
Minimum load (reference value)	100mA@5VDC

CHARACTERISTICS

Operate voltage	75% of nominal voltage or less	
Release voltage	5% of nominal voltage or more	
Operate time (At nominal voltage)	10ms max.	
Release time (At nominal voltage)	5ms max.	
Insulation resistance	1,000 MΩ min. (at 500 VDC)	
Dielectric strength	Between coil and contact	4,000 VAC, 50/60 Hz for 1 min
	Between open contacts	1,000 VAC, 50/60 Hz for 1 min
Surge voltage between coil and contacts	7,000V(1.2/50μs)	
Vibration resistance	Destructure	10 to 55 Hz, 1.5mm double amplitude
	Malfuction	10 to 55 Hz, 1.5mm double amplitude
Shock resistance	Destructure	1,000 m/s ² (100G approximately)
	Malfuction	100 m/s ² (10G approximately)
Ambient temperature	Operating: -40~+90°C (without icing or condensation)	
Ambient humidity	Operating: 5% to 85% RH	
Terminal	PCB terminals	
Enclosure (94V-0 Flammability Ratings)	V:	Vented(Flux-tight, RTII)
	S:	Sealed(Wash-tight, RTIII)
Weight	Approx. 4g	

ORDERING INFORMATION

	CHM	-V	-1	12	D	A	3	,000
1.Product Family								
2.Enclosure	V=Vented(Flux-tight, RTII) S=Sealed(Wash-tight, RTI)							
3.Number of Poles	1=1 pole							
4.Rated Coil Voltage	03,05,06,09,12,18,24,48VDC							
5.Coil Power	D = Standard(200mW)							
6.Contact Arrangement	A = Form A(SPST)							
7.Contact Material	3=AgSnO ₂ In ₂ O ₃ 2=AgNi							
8.Additional numbers and /or letters	000-999, AAA-ZZZ, aaa-zzz or blank, which does not represent electrical changes, only for specific customer requirements							

Typical products

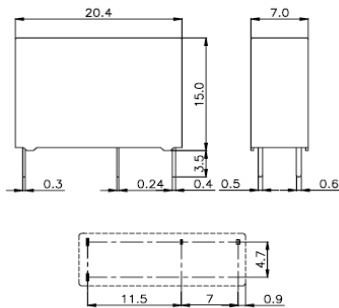

WIRING DIAGRAMS (BOTTOM VIEWS)



PC BOARD LAYOUTS (BOTTOM VIEWS)

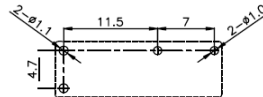

Remarks:

- The reference tolerance in outline dimer
outline dimension $\leq 1\text{mm}$, reference tolerance is \pm
outline dimension $> 1\text{mm}$ and $\leq 5\text{mm}$, reference tolerance is \pm
outline dimension $> 5\text{mm}$, reference tolerance is \pm
- The reference tolerance for PC Board layout is \pm

Reference Data

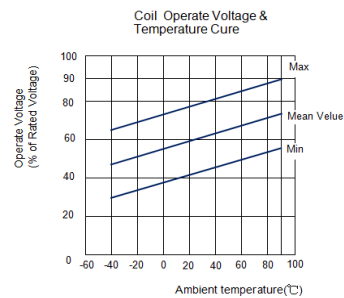
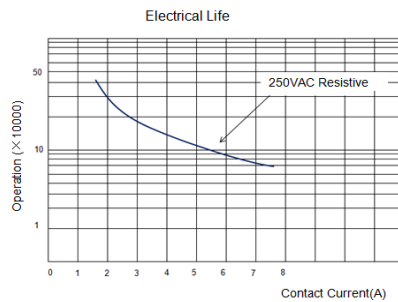
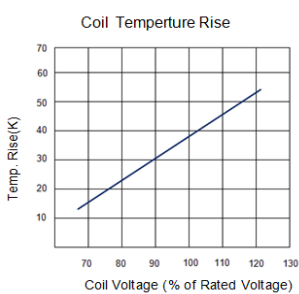

Packaging Figure

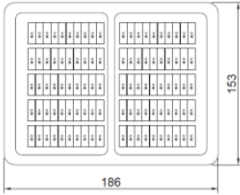

100 pcs inside a box
1000pcs inside a carton

2.TUBE

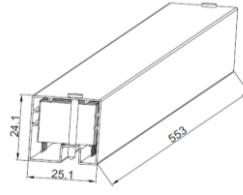

50 pcs inside a tube
2000 pcs inside a carton

Disclaimer:

The specification is for reference only,if you need more detail information,please contact Churod. We could not evaluate all the performance and all parameters for every possible application.And the user should be in a right position to choose the suitable product for their own application.If there is any new need,please contact Churod for the technical service.

[Http://www.churod.com](http://www.churod.com)

2022 Rev.04 Churod Electronics Co., Ltd.

FEATURES

- Outline dimension (19.2mm×15.5mm×15.3mm)
- 1 Form A (SPST) or 1 Form C (SPDT) contact arrangement
- Designed to meet cULus, TUV, CQC requirements
- Flux-tight and Wash-tight version available
- RoHS compliance
- REACH SvHC compliance
- Halogen-Free type available
- Glow wire type available

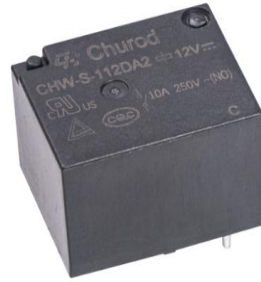

File NO. E341422



File NO. R50174892



File NO. CQC10002043606

APPLICATION

Appliances, Power Supplier, Industrial Control

COIL PARAMETER

Coil voltage	5-48VDC	
Coil power	Standard ver.	360mW

COIL DATA @23°C

CHW Standard				
Nominal coil voltage (VDC)	Nominal Current (mA)	Coil Resistance ($\Omega \pm 10\%$)	Operate Voltage (VDC)	Release Voltage (VDC)
5	72	69	3.75	0.25
6	60	100	4.5	0.3
9	40	225	6.75	0.45
12	30	400	9.0	0.6
18	20	900	13.5	0.9
24	15	1600	18.0	1.2
48	7.5	6400	36.0	2.4

Note:

- The data shown above are initial values.
- For the Sealed type, the venting-hole should be opened in electrical endurance test.

CONTACT DATA

Contact arrangement	1 Form A (SPST) / 1 Form C (SPDT)	
Contact material	Ag Alloy	
Initial contact resistance	100m Ω max.(at 6VDC,1A)	
Max. switching voltage	277VAC	
Max. switching current	15A(NO) / 6A(NC)	
Max. switching power	NO: 4155VA/450W	
	NC: 1662VA/180W	
Contact rating	NO :	15A @250VAC
		10A @250VAC
	NC:	10A @ 30VDC
		2A FLA,14A LRA @ 277VAC
	6A @ 250VAC	
	6A @ 30VDC	
Mechanical endurance	10,000,000 ops Min.(no load)	
Electrical endurance (Resistive Load)	NO: 15A 250VAC, 30,000 ops	
	NO: 10A 250VAC, 100,000 ops	
	NC: 6A 250VAC, 50,000 ops	
Minimum load (reference value)	100mA @5VDC	

CHARACTERISTICS

Operate voltage	75% of nominal voltage or less	
Release voltage	5% of nominal voltage or more	
Operate time (At nominal voltage)	10ms max.	
Release time (At nominal voltage)	5ms max.	
Insulation resistance	1,000 M Ω min. (at 500 VDC)	
Dielectric strength	Between coil and contacts	2,000 VAC, 50/60 Hz for 1 min
	Between open contacts	1,000 VAC, 50/60 Hz for 1 min
Surge voltage between coil and contacts	6,000V(1.2/50us)	
Vibration resistance	Destruction	10 to 55 Hz, 1.5mm double amplitude
	Malfunction	10 to 55 Hz, 1.5mm double amplitude
Shock resistance	Destruction	1,000m/S ² (100G approximately)
	Malfunction	1,00m/S ² (10G approximately)
Ambient temperature	-40~+85°C (without icing or condensation)	
Ambient humidity	20%~85% RH	
Termination	PCB terminals	
Enclosure (94V-0 Flammability Ratings)	V: Vented(Flux-tight, RTII)	
	S: Sealed(Wash-tight, RTIII)	
Unit Weight	Approx. 9g	

ORDERING INFORMATION

	CHW	-V	-1	12	D	A	2	--	,000
1. Product Family									
2. Enclosure	V = Vented (Flux-tight, RTII) S = Sealed (Wash-tight, RTIII)								
3. Number of Poles	1=1 pole								
4. Rated Coil Voltage	05,06,09,12,18,24,48VDC								
5.Coil Power	D = Standard (360mW)								
6. Contact Arrangement	A = Form A(SPST) C = Form C(SPDT)								
7.Contact material	2=AgSnO ₂								
8.Conact Capacity	Blank = 10/15A								
9. Additional numbers and /or letters	000-999, AAA-ZZZ, aaa-zzz or blank, which does not represent electrical changes, only for specific customer requirements,ex: (15A)=15A								

OUTLINE DIMENSION

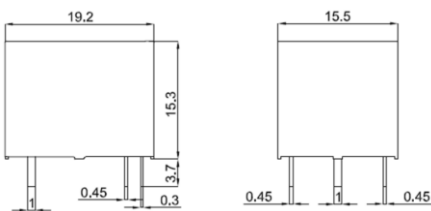

WIRING DIAGRAMS (BOTTOM VIEWS)

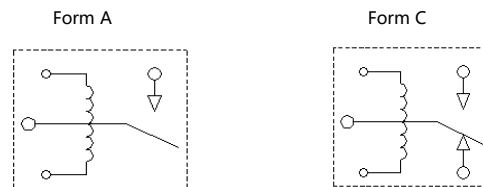

PC BOARD LAYOUTS (BOTTOM VIEWS)

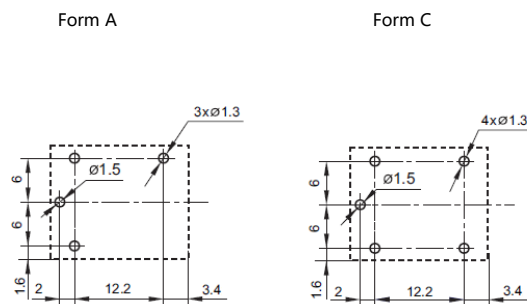

Remark:

- The reference tolerance in outline dimension:
 - outline dimension ≤ 1 mm, reference tolerance is ± 0.2 mm;
 - outline dimension > 1 mm and ≤ 5 mm, reference tolerance is ± 0.3 mm;
 - outline dimension > 5 mm, reference tolerance is ± 0.5 mm.
- The reference tolerance for PC Board layout is ± 0.1 mm.

FEATURES

- Outline dimension (20mm×15.5mm×20.2mm)
- 1 Form A (SPST) or 1 Form C (SPDT) contact arrangement
- Flux-tight and Wash-tight version available
- RoHS compliance
- REACH SvHC compliance
- Halogen-Free type available
- Glow wire type available



File NO. E341422



File NO. R50254542



File NO. CQC21002285907

APPLICATION

Appliances, Power Supplies, Industrial Control, Photo control

COIL PARAMETER

Coil voltage	5-48VDC	
Coil power	Standard ver.	360mW

COIL DATA @23°C

CHW Standard				
Nominal coil voltage (VDC)	Nominal Current (mA)	Coil Resistance ($\Omega \pm 10\%$)	Operate Voltage (VDC)	Release Voltage (VDC)
5	72	69	3.75	0.25
6	60	100	4.5	0.3
9	40	225	6.75	0.45
12	30	400	9.0	0.6
18	20	900	13.5	0.9
24	15	1600	18.0	1.2
48	7.5	6400	36.0	2.4

CONTACT DATA

Contact arrangement	1 Form A (SPST) / 1 Form C (SPDT)	
Contact material	Ag Alloy	
Initial contact resistance	100m Ω max.(at 6VDC,1A)	
Max. switching voltage	277VAC	
Max. switching current	20A(NO) / 10A(NC)	
Max. switching power	NO : 5540VA	
	NC : 2770VA	
Contact rating	NO :	20A @277VAC, 30K ops, 85°C
		17A @277VAC, 30K ops, 105°C
		TV-8 @ 250VAC, 25K ops, 85°C
		1HP @ 250VAC, 100K ops, 85°C
	NC:	10A @ 277VAC, 50K ops, 85°C
Mechanical endurance	10,000,000 ops Min.(no load)	
Electrical endurance (Resistive Load)	NO: 20A 250VAC, 30,000 ops	
	NO: 17A 250VAC, 100,000 ops	
	NC: 10A 250VAC, 50,000 ops	
Minimum load (reference value)	100mA @5VDC	

Note:

- The data shown above are initial values.
- For the Sealed type, the venting-hole should be opened in electrical endurance test.

CHARACTERISTICS

Operate voltage	75% of nominal voltage or less	
Release voltage	5% of nominal voltage or more	
Operate time (At nominal voltage)	10ms max.	
Release time(At nominal voltage)	5ms max.	
Insulation resistance	1,000 M Ω min. (at 500 VDC)	
Dielectric strength	Between coil and contacts	2,000 VAC, 50/60 Hz for 1 min
	Between open contacts	1,000 VAC, 50/60 Hz for 1 min
Surge voltage between coil and contacts	6,000V(1.2/50us)	
Vibration resistance	Destruction	10 to 55 Hz, 1.5mm double amplitude
	Malfunction	10 to 55 Hz, 1.5mm double amplitude
Shock resistance	Destruction	1,000m/S ² (100G approximately)
	Malfunction	1,00m/S ² (10G approximately)
Ambient temperature	17A: '-40~+105°C (without icing or condensation) 20A: '-40~+85°C (without icing or condensation)	
Ambient humidity	20%~85% RH	
Termination	PCB terminals	
Enclosure (94V-0 Flammability Ratings)	V: Vented(Flux-tight, RTII)	
	S: Sealed(Wash-tight, RTIII)	
Unit Weight	Approx. 11g	

ORDERING INFORMATION

	CHW	-V	-1	12	D	A	2	H	,000
1. Product Family									
2. Enclosure V = Vented (Flux-tight, RTII) S = Sealed (Wash-tight, RTIII)									
3. Number of Poles 1=1 pole									
4. Rated Coil Voltage 05,06,09,12,18,24,48VDC									
5.Coil Power D = Standard (360mW)									
6. Contact Arrangement A = Form A(SPST) C = Form C(SPDT)									
7.Contact material 2=AgSnO ₂									
8.Concact Capacity H = 17/20A									
9. Additional numbers and /or letters 000-999, AAA-ZZZ, aaa-zzz or blank, which does not represent electrical changes, only for specific customer requirements,ex: (20A)=20A									

OUTLINE DIMENSION

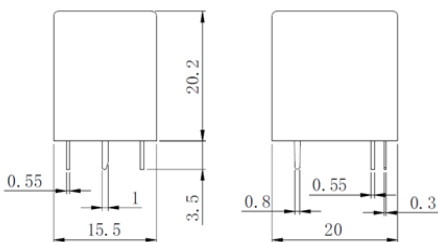

WIRING DIAGRAMS (BOTTOM VIEWS)

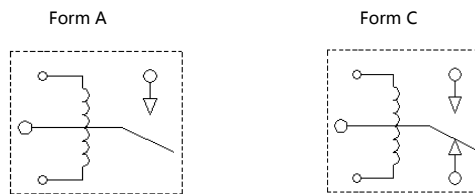

PC BOARD LAYOUTS (BOTTOM VIEWS)

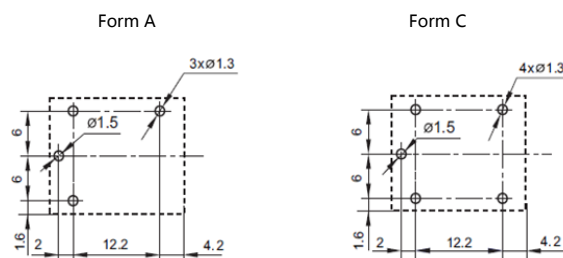

Remark:

- The reference tolerance in outline dimension:
outline dimension ≤ 1 mm, reference tolerance is ± 0.2 mm;
outline dimension > 1 mm and ≤ 5 mm, reference tolerance is ± 0.3 mm;
outline dimension > 5 mm, reference tolerance is ± 0.5 mm.
- The reference tolerance for PC Board layout is ± 0.1 mm.

CHI03 SERIES 17A MINIATURE POWER RELAY

FEATURES

- Outline dimension(29.3×12.7×15.3)
- 1 Form A(SPST-NO) and 1 Form C(SPDT) contact arrangement
- Designed to meet UL/cUL,TUV,CQC requirements
- 5,000VAC dielectric strength between coil and contact
- F class Insulation System
- RoHS compliance
- REACH SvHC compliance
- Halogen-Free type available

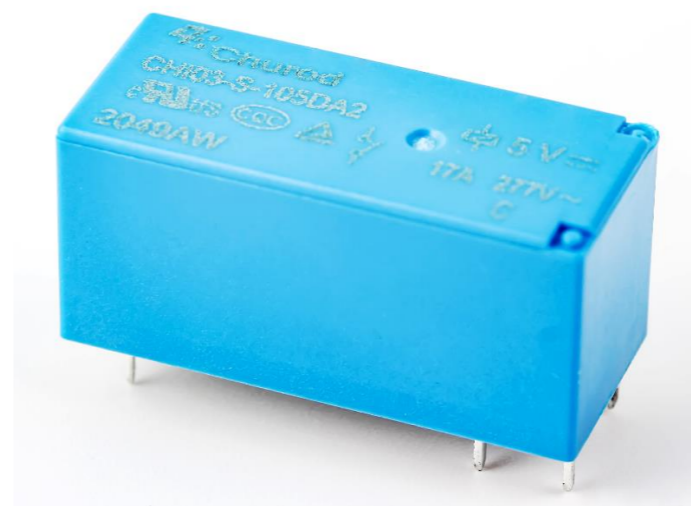

File NO. E341422



File NO. R50384623



File NO. CQC17002177358

APPLICATION

Appliances, power supply, Industrial Control...etc

COIL PARAMETER

Coil voltage	3-110VDC
Coil power	400mW

COIL DATA@23°C

CHI03				
Nominal coil voltage (VDC)	Nominal Current (mA)	Coil Resistance ($\Omega \pm 10\%$)	Operate Voltage (VDC Max.)	Release Voltage (VDC Min.)
3	133.3	22.5	2.25	0.15
5	80.0	62.5	3.75	0.25
6	66.7	90	4.5	0.3
9	44.4	202.5	6.75	0.45
12	33.3	360	9	0.6
18	22.2	810	13.5	0.9
22	18.2	1210	16.5	1.1
24	16.7	1440	18	1.2
36	11.1	3240	27	1.8
48	8.3	5760	36	2.4
60	6.7	9000	45	3
110	3.6	30250	82.5	5.5

CONTACT DATA

Contact arrangement	1 Form A(SPST-NO), 1 Form C(SPDT), 1 Form B(SPST-NC)
Contact material	Ag Alloy
Initial contact resistance	100m Ω max.@6VDC,1A
Max. switching voltage	277VAC/30VDC
Max. switching current	20A
Max. switching power	5540VA / 600W
Contact rating	NO
	17A @277VAC/30VDC
	1HP @120/240/480VAC
	10FLA/60LRA @250VAC
	5A pilot duty @120VAC and 277VAC
	16A general purpose @120VAC and 277VAC
	20A @277VAC resistive, 30K cycles
	TV-8 @120VAC 25K cycles
	NC
	1HP @120/240/480VAC
10FLA/60LRA @250VAC	
5A pilot duty @120VAC and 277VAC , 30K cycles	
17A @277VAC/30VDC , 30K cycles	
16A general purpose @120VAC and 277VAC , 30K cycles	
Mechanical endurance	10,000,000 ops Min.(no load)
Electrical endurance	100,000 ops Min.(rated load 1s on /9s off)
Minimum load(reference value)	100mA @5VDC

CHARACTERISTICS

Operate voltage	75% of nominal voltage or less	
Release voltage	5% of nominal voltage or more	
Operate time (At nominal voltage)	15ms max.	
Release time(At nominal voltage)	8ms max.	
Insulation resistance	1,000 M Ω min. (at 500 VDC)	
Insulation system	155 (F)	
Dielectric strength	Between coil and contacts	5,000 VAC, 50/60 Hz for 1 min
	Between open contacts	1,000 VAC, 50/60 Hz for 1 min
Surge voltage between coil and contacts	10,000V(1.2/50us)	
Vibration resistance	Destruction	10 to 55 Hz.,1.5mm double amplitude
	Malfunction	10 to 55 Hz.,1.5mm double amplitude
Shock resistance	Destruction	1,000m/S ² (100G approximately)
	Malfunction	100m/S ² (10G approximately)
Ambient temperature	-40°C~+105°C (without icing or condensation)	
Ambient humidity	20%~85% RH	
Terminal	PCB terminal	
Enclosure (94V-0 Flammability Ratings)	V: Vented(Flux-tight),plastic cover.(RT II)	
	S: Sealed,plastic cover.(RT III)	
Weight	Approx. 14g	

ORDERING INFORMATION

CHI03	-V	-1	12	D	A	2	,000
1. Product Family							
2. Enclosure V = Vented (Flux-tight), plastic cover. (RT II) S = Sealed, plastic cover. (RT III)							
3. Number of Poles 1 = 1 pole							
4. Rated Coil Voltage 03, 05, 06, 09, 12, 18, 22, 24, 36, 48, 60, 110VDC							
5. Coil Input D = Standard (400mW)							
6. Contact Arrangement A = Form A (SPST-NO) B = Form B (SPST-NC) C = Form C (SPDT)							
7. Contact material 2 = AgSnO ₂							
8. Additional numbers and /or letters 000-999, AAA-ZZZ, aaa-zzz or blank, which does not represent electrical changes, only for specific customer requirements							

OUTLINE DIMENSION

From A

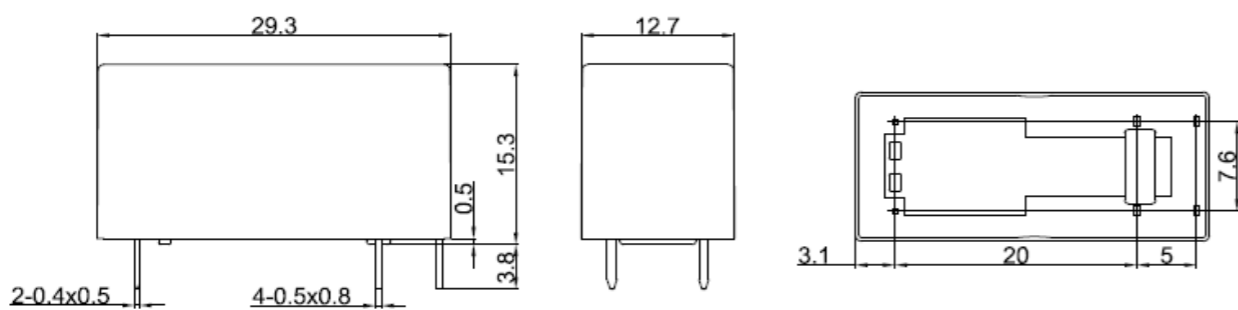

From B

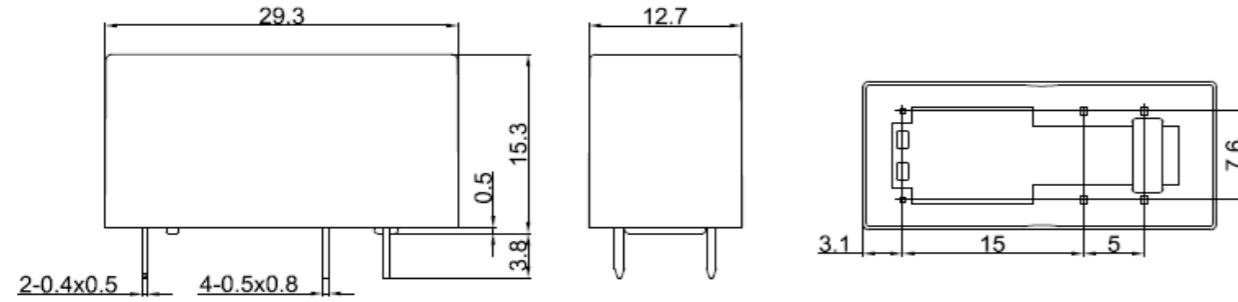

From C

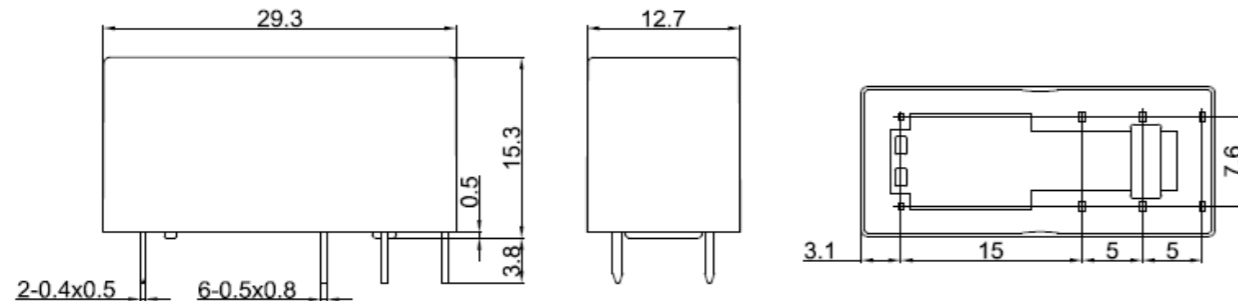

WIRING DIAGRAMS (BOTTOM VIEWS)

From A

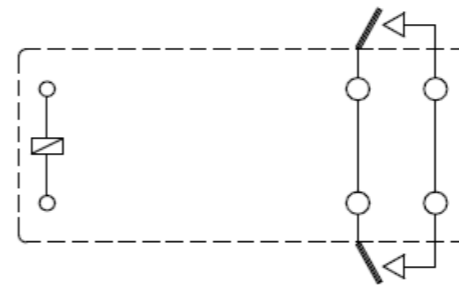

From B

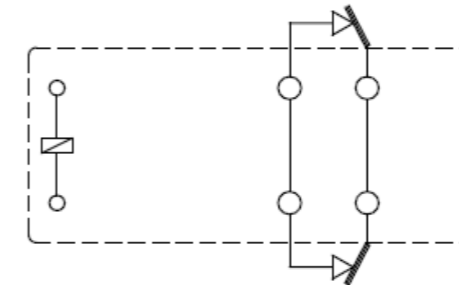

From C

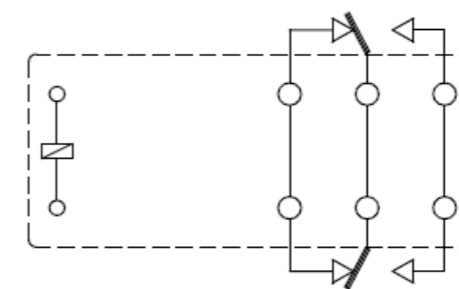

PC BOARD LAYOUTS (BOTTOM VIEWS)

Remark:

- The reference tolerance in outline dimension:
outline dimension ≤ 1 mm, reference tolerance is ± 0.2 mm;
outline dimension > 1 mm and ≤ 5 mm, reference tolerance is ± 0.3 mm;
outline dimension > 5 mm, reference tolerance is ± 0.5 mm.
- The reference tolerance for PC Board layout is ± 0.1 mm.

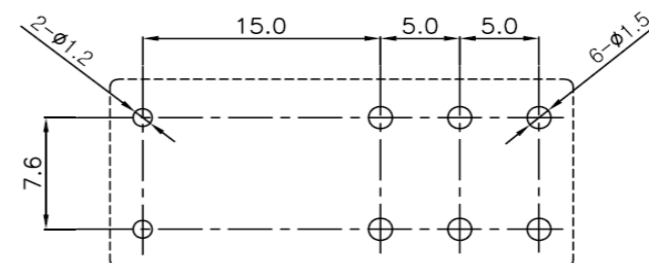

REFERENCE DATA

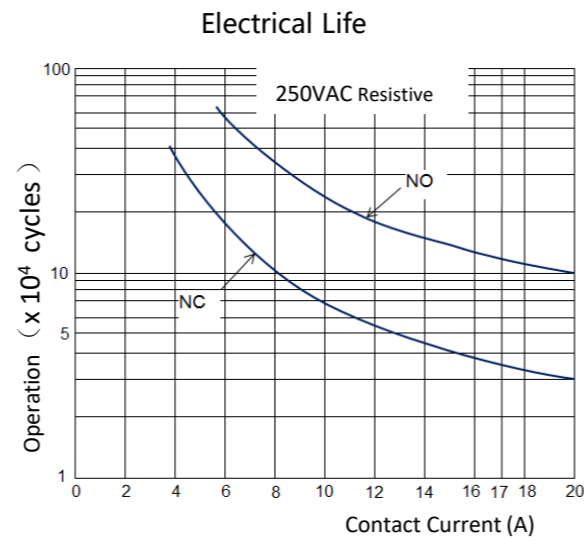
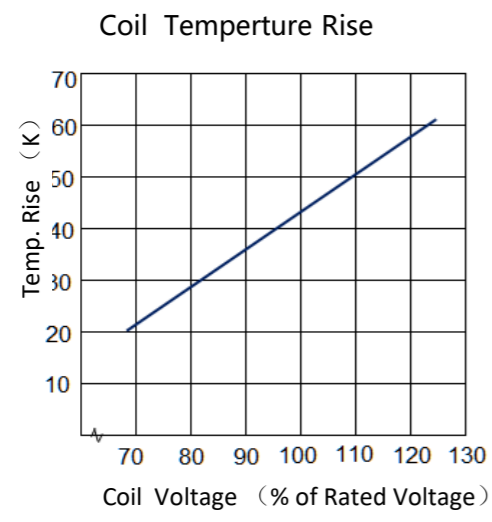

Coil Operate Voltage & Temperature Cure

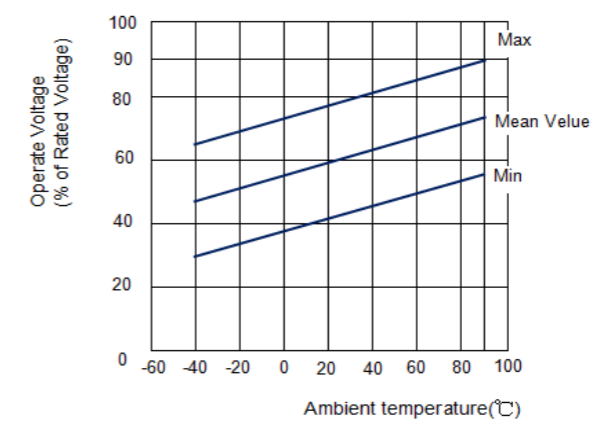

PACKAGING FIGURE

1.Box

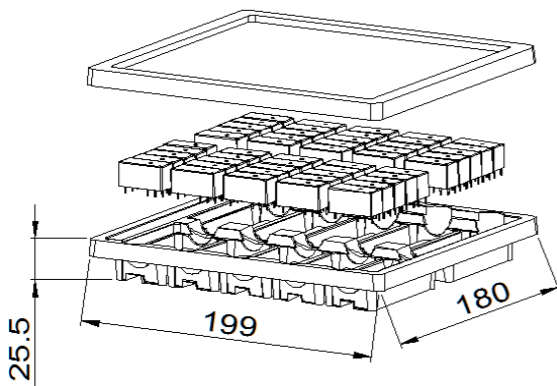

50 pcs inside a box
500 pcs inside a carton

2.Tube

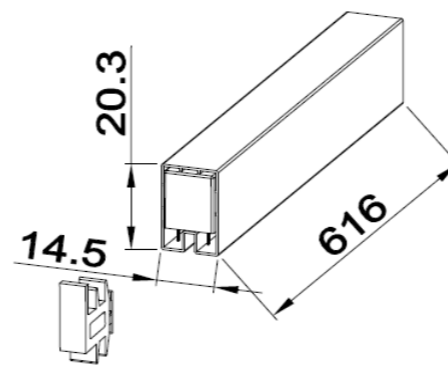

20 pcs inside a tube
1000 pcs inside a carton

Disclaimer:

The specification is for reference only, if you need more detail information, please contact Churod. We could not evaluate all the performance and all parameters for every possible application. And the user should be in a right position to choose the suitable product for their own application. If there is any new need, please contact Churod for the technical service.

[Http://www.churod.com](http://www.churod.com)

2020 Rev.01 Churod Electronics Co., Ltd.

FEATURES

- Outline dimension(30.3×15.9×20.4)
- 1 Form A(SPST-NO) arrangement
- Designed to meet UL/cUL,TUV,CQC requirements
- 4,500VAC dielectric strength between coil and contact
- F class Insulation System
- RoHS compliance
- REACH SvHC compliance
- Halogen-Free type available



File NO. E341422



File NO. R50366268



File NO. CQC16002152596

APPLICATION

Air Conditioner, Micro-oven, Washing Machine...etc

COIL PARAMETER

Coil voltage	5-48VDC
Coil power	900mW

COIL DATA@23°C

CHE				
Nominal coil voltage (VDC)	Nominal Current (mA)	Coil Resistance ($\Omega \pm 10\%$)	Operate Voltage (VDC Max.)	Release Voltage (VDC Min.)
5	180.0	28	3.75	0.25
6	150.0	40	4.5	0.30
9	100.0	90	6.75	0.45
12	75.0	160	9	0.60
18	50.0	360	13.5	0.90
24	37.5	640	18	1.20
48	18.8	2560	36	2.40

CONTACT DATA

Contact arrangement	1 Form A(SPST-NO)
Contact material	Ag Alloy
Initial contact resistance	100m Ω max.@6VDC,1A
Max. switching voltage	277VAC/30VDC
Max. switching current	30A
Max. switching power	8,310VA / 900W
Contact rating	20A 277VAC, Resistive
	25A 277VAC, Resistive
	20A 30VDC, Resistive
	30A 250VAC, Resistive for QC type,30K cycles
	25A 250VAC, Inductive(cos ϕ =0.75)
	25A stable current , 85A Inrush current, 250VAC
2HP 250VAC Motor	
Mechanical endurance	10,000,000 ops Min.(no load)
Electrical endurance	100,000 ops Min.(rated load 1s on /9s off)
Minimum load(reference value)	100mA @5VDC

CHARACTERISTICS

Operate voltage	75% of nominal voltage or less	
Release voltage	5% of nominal voltage or more	
Operate time (At nominal voltage)	20ms max.	
Release time(At nominal voltage)	20ms max.	
Insulation resistance	1,000 M Ω min. (at 500 VDC)	
Insulation system	155 (F)	
Dielectric strength	Between coil and contacts	4,500 VAC, 50/60 Hz for 1 min
	Between open contacts	1,000 VAC, 50/60 Hz for 1 min
Surge voltage between coil and contacts	10,000V(1.2/50us)	
Vibration resistance	Destruction	10 to 55 Hz,1.5mm double amplitude
	Malfunction	10 to 55 Hz,1.5mm double amplitude
Shock resistance	Destruction	1,000m/S ² (100G approximately)
	Malfunction	100m/S ² (10G approximately)
Ambient temperature	-40°C~ +85°C (without icing or condensation)	
Ambient humidity	20%~85% RH	
Terminal	PCB terminal & #250 Quick connect terminal	
Enclosure (94V-0 Flammability Ratings)	V: Vented(Flux-tight),plastic cover.(RT II)	
	S: Sealed,plastic cover.(RT III)	
Weight	Approx. 20g	

Reference Data

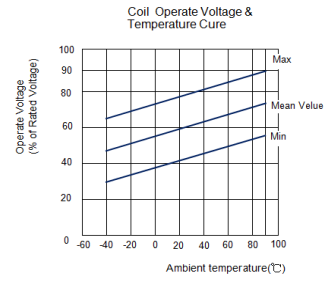
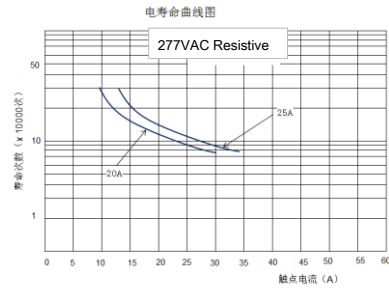
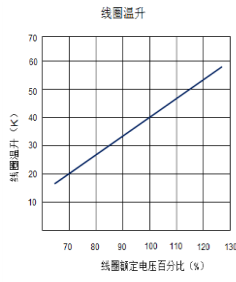

PACKAGING FIGURE

1.Box

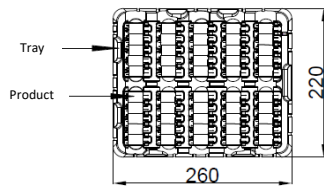

50 pcs inside a box
500 pcs inside a carton

2.Tube

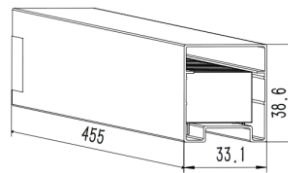

25 pcs inside a tube
500 pcs inside a carton

Disclaimer:

The specification is for reference only, if you need more detail information, please contact Churod. We could not evaluate all the performance and all parameters for every possible application. And the user should be in a right position to choose the suitable product for their own application. If there is any new need, please contact Churod for the technical service.

[Http://www.churod.com](http://www.churod.com)

2021 Rev.01 Churod Electronics Co., Ltd.

FEATURES

- CHS01: Outline dimension (32.1mm×27.05mm×20.2mm)
- CHS02: Outline dimension (32.5mm×27.3mm×19.9mm)
- 1 Form A or 1 Form B and 1 Form C contact arrangement
- Designed to meet cULus,TUV,CQC requirements
- Flux-tight and Wash-tight version available
- RoHS REACH SvHC compliance
- Halogen-Free type available
- Glow wire type available



File NO. E341422



File NO. R50271657



File NO. CQC13002102346

APPLICATION

Appliances, Power Supplier, Industrial Control

COIL PARAMETER

Coil voltage	5-110VDC	
Coil power	Standard ver.	900mW

COIL DATA @23°C

CHS-L				
Nominal coil voltage (VDC)	Nominal Current (mA)	Coil Resistance ($\Omega \pm 10\%$)	Operate Voltage (VDC Max.)	Release Voltage (VDC Min.)
5	180	27.8	3.75	0.25
6	150	40	4.5	0.3
9	100	90	6.75	0.45
12	75	160	9	0.6
15	60	250	11.25	0.75
18	50	360	13.5	0.9
22	40.9	537.8	16.5	1.1
24	37.5	640	18	1.2
36	25	1440	27	1.8
48	18.8	2560	36	2.4
60	15	4000	45	3
110	8.2	13444	82.5	5.5

Note:

1) The data shown above are initial values.

CONTACT DATA

Contact arrangement	1 Form A (SPST) / 1 Form B (SPST) / 1 Form C (SPDT)		
Contact material	Ag Alloy		
Initial contact resistance	100m Ω max.(at 6VDC,1A)		
Max. switching voltage	277VAC/30VDC		
Max. current	Switching	40A(NO) / 30A(NC)	
	Carrying	60A(NO) / 30A(NC)	
Max. power	Switching	NO : 11,080VA / NC : 8310VA	
	Carrying	NO : 16,620VA / NC : 8310VA	
Contact rating	Form A	LA/LA2	30A @ 277VAC
			40A @ 277VAC
			2HP @ 250VAC
	Form C	LC	15A-50A-15A @ 250VAC, Make-Carry-Break
			15A-60A-15A @ 250VAC, Make-Carry-Break
			20A(N.O)/10A(N.C) @ 277VAC
Form B	LC2	40A(N.O)/25A(N.C) @ 277VAC	
		40A(N.O)/30A(N.C) @ 277VAC	
Form B	30A @ 277VAC		
Mechanical endurance	1,000,000 ops Min.(no load)		
Electrical endurance (Resistive Load)	NO: 15A-60A/50A-15A @ 250VAC, Make-Carry-Break ,30,000 ops T85		
	NO: 40A 250VAC,30,000 ops T85		
	NO: 30A 250VAC,100,000 ops T85		
	NC: 30A 250VAC,10,000 ops T85		
Minimum load (reference value)	100mA @5VDC		

CHARACTERISTICS

Operate voltage	75% of nominal voltage or less	
Release voltage	5% of nominal voltage or more	
Operate time (At nominal voltage)	15ms max.	
Release time (At nominal voltage)	15ms max.	
Insulation resistance	1,000 M Ω min. (at 500 VDC)	
Dielectric strength	Between coil and contacts	2,500 VAC, 50/60 Hz for 1 min
	Between open contacts	1,500 VAC, 50/60 Hz for 1 min
Surge voltage between coil and contacts	6,000V(1.2/50 μ s)	
Vibration resistance	Destruction	10 to 55 Hz.,1.5mm double amplitude
	Malfunction	10 to 55 Hz.,1.5mm double amplitude
Shock resistance	Destruction	1,000m/S ² (100G approximately)
	Malfunction	1,00m/S ² (10G approximately)
Ambient temperature	-40~ +85°C (without icing or condensation)	
Ambient humidity	20%~85% RH	
Termination	PCB terminals	
Enclosure (94V-0 Flammability Ratings)	V: Vented(Flux-tight, RTII)	
	S: Sealed(Wash-tight, RTIII)	
Unit Weight	Approx. 26g(CHS01), Approx. 32g(CHS02)	

ORDERING INFORMATION

	CHS01	-V	-1	12	L	A	2	(60A)	,000
1. Product Family CHS01:PCB terminal CHS02:PCB & 250QC terminal									
2. Enclosure V = Vented (Flux-tight, RTII) S = Sealed (Wash-tight, RTIII) (only 40A and blow)									
3. Number of Poles 1=1 pole									
4. Rated Coil Voltage 05,06,09,12,18,22,24,48,60,110VDC									
5.Coil Power L = Standard (900mW)									
6. Contact Arrangement A = Form A(SPST) B = Form B(SPST) C = Form C(SPDT)									
7.Contact material Blank = AgCdO(40A and down) 2 = AgSnO ₂									
8. Rated Current (40A)=40A (50A)=50A (60A)=60A									
9. Additional numbers and /or letters 000-999 , AAA-ZZZ , aaa-zzz or blank , only for specific customer requirements,ex:(30A)=30A,(50A)=50A,(60A)=60A ...									

OUTLINE DIMENSION

Unit: mm

CHS01 (Rated Current ≤ 40A)

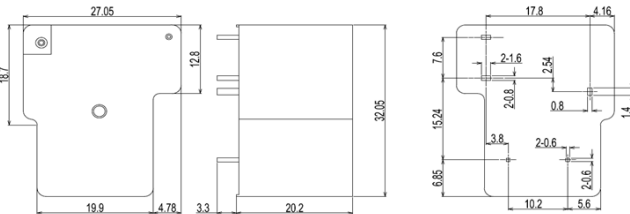

CHS01 (Rated Current > 40A)

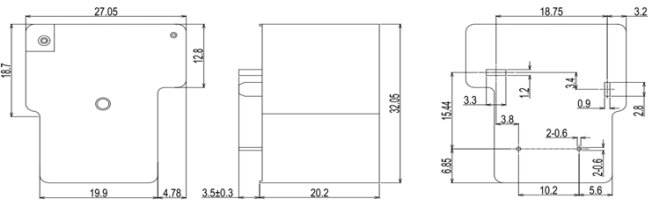

CHS02

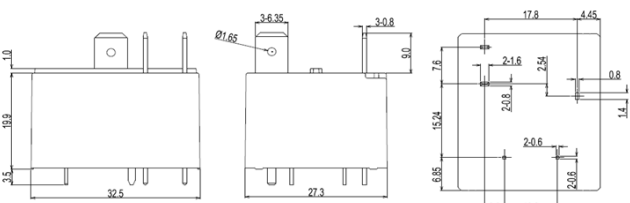

CHS02 (G Series)

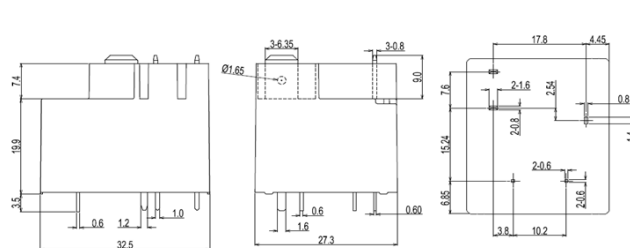

WIRING DIAGRAMS (BOTTOM VIEWS)

CHS01 Form C

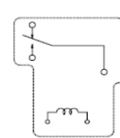

CHS02/CHS02(G Series) Form C

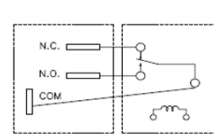

CHS01 Form A

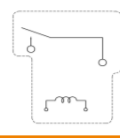

CHS02/CHS02(G Series) Form A

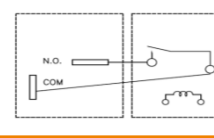

PC BOARD LAYOUTS (BOTTOM VIEWS)

CHS01 (≤40A) Form C

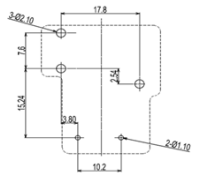

CHS02/CHS02(G Series) Form C

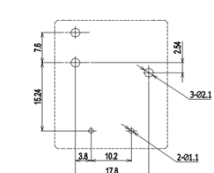

CHS01 (≤40A) Form A

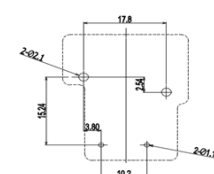

CHS02/CHS02(G Series) Form A

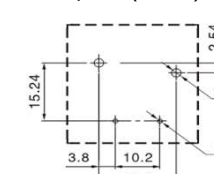

CHS01 (>40A) Form A

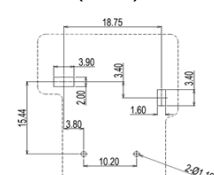

Remark:

- 1)The reference tolerance in outline dimension:
 outline dimension ≤ 1mm, reference tolerance is ±0.2mm;
 reference tolerance is ±0.2mm;
 outline dimension > 1mm and ≤ 5mm,
 reference tolerance is ±0.3mm;
 outline dimension > 5mm,
 reference tolerance is ±0.5mm.
- 2)The reference tolerance for PC Board layout is ±0.1mm.

REFERENCE DATA

Coil Temperature Rise

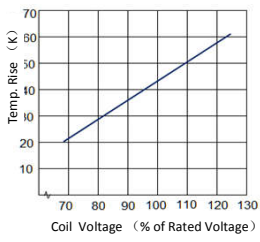

Electrical Life

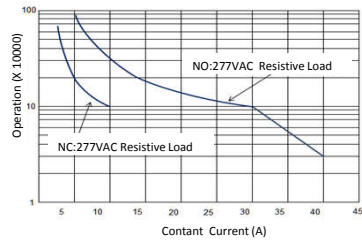

Coil Operate/Release Voltage & Temperature Cure

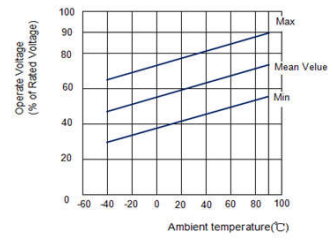

PACKAGING FIGURE

Tube

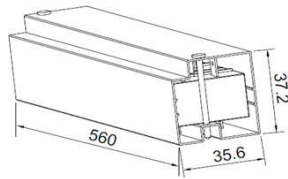
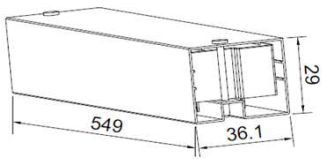

20 pcs inside a tube

500 pcs inside a carton

Disclaimer :

The specification is for reference only, if you need more detail information, please contact Churod. We could not evaluate all the performance and all parameters for every possible application.

And the user should be in a right position to choose the suitable product for their own application. If there is any new need, please contact Churod for the technical service.

[Http://www.churod.com](http://www.churod.com)

2022 Rev.01 Churod Electronics Co., Ltd.

FEATURES

- Outline dimension (29.3mm×12.7mm×15.3mm)
- Latching relay
- 1 Form A (SPST) or 1 Form C (SPDT) contact arrangement
- Designed to meet cULus, TUV, CQC requirements
- Flux-tight and Wash-tight version available
- RoHS compliance
- REACH SvHC compliance
- Halogen-Free type available
- Glow wire type available



File NO. E341422



File NO. R50422926



File NO. CQC18002208792

APPLICATION

Appliances, Power Supplier, Industrial Control

COIL PARAMETER

Coil voltage	3-48VDC	
Coil power	1 Coil latching	400mW
	2 Coil latching	600mW

COIL DATA @23°C

D type--1 Coil latching type (at 23°C)				
Nominal coil voltage (VDC)	Nominal Current (mA)	Coil Resistance (Ω±10%)	Operate Voltage (VDC Max.)	Release Voltage (VDC Max.)
3	133.3	22.5	2.25	2.25
5	80	62.5	3.75	3.75
6	66.7	90	4.5	4.5
9	44.4	202.5	6.75	6.75
12	33.3	360	9	9
18	22.2	810	13.5	13.5
24	16.7	1440	18	18
36	11.1	3240	27	27
48	8.3	5760	36	36

H type--2 Coil latching type (at 23°C)				
Nominal coil voltage (VDC)	Nominal Current (mA)	Coil Resistance (Ω±10%)	Operate Voltage (VDC Max.)	Release Voltage (VDC Max.)
3	200	15	2.25	2.25
5	120	41.7	3.75	3.75
6	100	60	4.5	4.5
9	66.7	135	6.75	6.75
12	50	240	9	9
18	33.3	540	13.5	13.5
24	25	960	18	18
36	16.7	2160	27	27
48	12.5	3840	36	36

Note:

- The data shown above are initial values.

CONTACT DATA

Contact arrangement	1 Form A (SPST) / 1 Form C (SPDT)	
Contact material	Ag Alloy	
Initial contact resistance	100mΩ max.(at 6VDC,1A)	
Max. switching voltage	277VAC	
Max. switching current	20A(NO) / 5A(NC)	
Max. switching power	NO: 5540VA	
	NC: 1385VA	
Contact rating	NO :	12A @ 277VAC
		17A @ 277VAC
		20A @ 277VAC
		1HP @ 240VAC
		TV-8 @ 240VAC
		Tungsten 1500W @ 120VAC
		Tungsten 3000W @ 240VAC
		Electronic ballast 8A @ 277VAC
		EM Ballast 3.7A @ 480VAC
		NC:
Mechanical endurance	1,000,000 ops Min.(no load)	
Electrical endurance (Resistive Load)	NO: 12A @ 277VAC,100,000 ops T85	
	NO: 17A @ 277VAC,50,000 ops T85	
	NO: 20A @ 277VAC,30,000 ops T85	
	NC: 5A @ 277VAC,50,000 ops T85	
Minimum load (reference value)	100mA @5VDC	

CHARACTERISTICS

Operate voltage	75% of nominal voltage or less	
Release voltage	75% of nominal voltage or less	
Operate time (At nominal voltage)	15ms max.	
Release time (At nominal voltage)	15ms max.	
Insulation resistance	1,000 MΩ min. (at 500 VDC)	
Dielectric strength	Between coil and contacts	5,000 VAC, 50/60 Hz for 1 min
	Between open contacts	1,000 VAC, 50/60 Hz for 1 min
Surge voltage between coil and contacts	10,000V(1.2/50us)	
Vibration resistance	Destruction	10 to 55 Hz, 1.5mm double amplitude
	Malfunction	10 to 55 Hz, 1.5mm double amplitude
Shock resistance	Destruction	1,000m/S ² (100G approximately)
	Malfunction	1,00m/S ² (10G approximately)
Ambient temperature	-40~+85°C (without icing or condensation)	
Ambient humidity	20%~85% RH	
Pulse Duration	50ms Min.	
Termination	PCB terminals	
Enclosure	V: Vented(Flux-tight, RTII)	

ORDERING INFORMATION

CHI03

L

-V

-1

12

D

A

2

,000

1. Product Family

CHI03: 17A, Contact terminal pin 5.0mm (code 3)

2. Coil System

L = Latching version

3. Enclosure

V = Vented (Flux-tight, RTII)

S = Sealed (Wash-tight, RTIII)

4. Number of Poles

1=1 pole

5. Rated Coil Voltage

03,05,06,09,12,18,24,36,48VDC

6.Coil Power

D = 1 coil latching 400mW H = 2 coil latching 600mW

7. Contact Arrangement

A = Form A(SPST) C = Form C(SPDT)

8.Contact material

2=AgSnO₂

9. Additional numbers and /or letters

000-999, AAA-ZZZ, aaa-zzz or blank, which does not represent electrical changes, only for specific customer requirements

OUTLINE DIMENSION

1 coil latching type

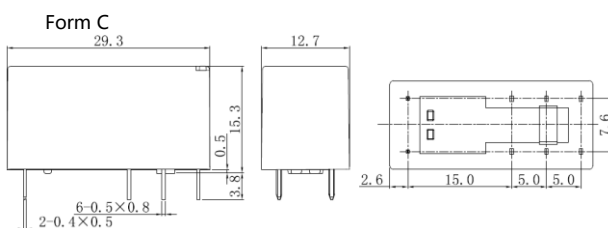
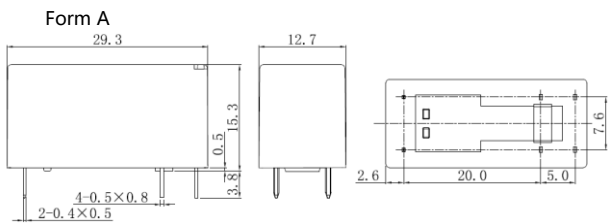

2 coil latching type

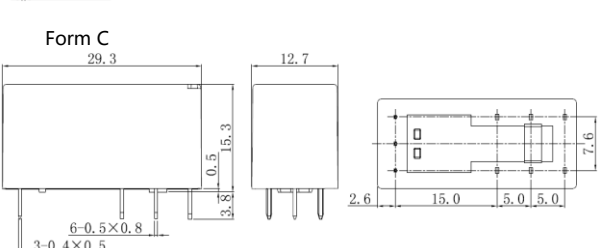
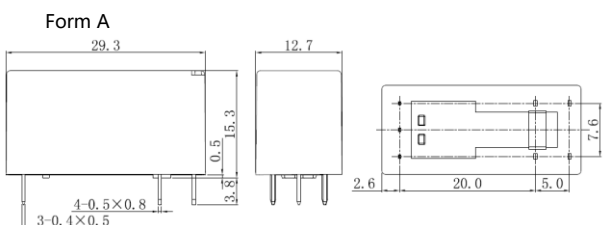

WIRING DIAGRAMS (BOTTOM VIEWS)

1 coil latching type

Form A



Form C

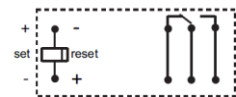

2 coil latching type

Form A

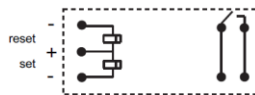

Form C

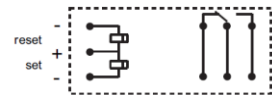

PC BOARD LAYOUTS (BOTTOM VIEWS)

1 coil latching type

Form A

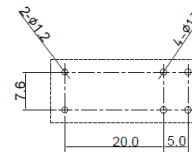

Form C

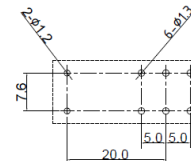

2 coil latching type

Form A

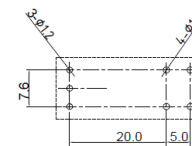

Form C

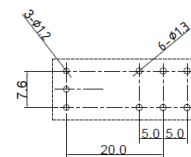

Remark:

1) The reference tolerance in outline dimension:

outline dimension $\leq 1\text{mm}$, reference tolerance is $\pm 0.2\text{mm}$;

outline dimension $> 1\text{mm}$ and $\leq 5\text{mm}$, reference tolerance is $\pm 0.3\text{mm}$;

outline dimension $> 5\text{mm}$, reference tolerance is $\pm 0.5\text{mm}$.

2) The reference tolerance for PC Board layout is $\pm 0.1\text{mm}$.

3) Relay is on the "reset" or "set" status when being released from stock, with the consideration of shock risen from transit and relay mounting, relay would be changed to "set" or "reset" status, therefore, when application (connecting the power supply), please rest the relay to "set" or "reset" status on request.

[Http://www.churod.com](http://www.churod.com)

2020 Rev.01 Churod Electronics Co., Ltd.

REFERENCE DATA

Electrical Life

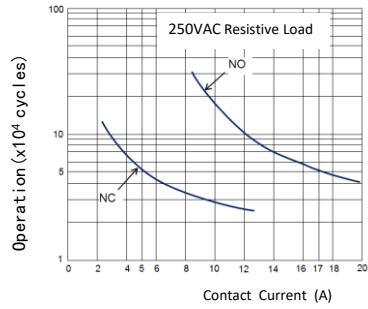

Coil Operate/Release Voltage & Temperature Cure

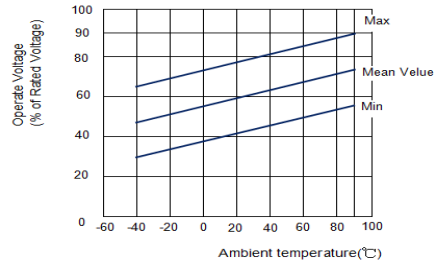

PACKAGING FIGURE

Box

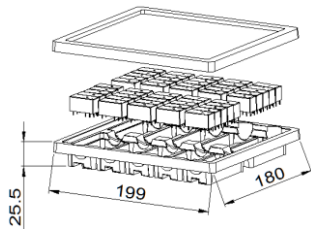

50 pcs inside a box

500 pcs inside a carton

Disclaimer:

The specification is for reference only, if you need more detail information, please contact Churod. We could not evaluate all the performance and all parameters for every possible application.

And the user should be in a right position to choose the suitable product for their own application. If there is any new need, please contact Churod for the technical service.

[Http://www.churod.com](http://www.churod.com)

2020 Rev.01 Churod Electronics Co., Ltd.

CHUROD ELECTRONICS

Everything we do is for our customers' advantage



Dongguan Churod Electronics Co., Ltd.

Unit 20, Xin Gui Road, Lin Village
TangXia Town, Dongguan
GuangDong, PR China 523711
T: +86-769-3906688 F: +86-769-82996568
www.churod.com

Churod Americas, Inc.

485 Devon Park Drive
Suite 118
Wayne, PA 19087
T: +1-610-608-1547
www.churodamericas.com

Churod Europe

Str. D-na Stanca #38
Sibiu, Romania
T: 00-40-744-517-452
www.churodeurope.com