

## FEATURES

- Ceramic brazing sealed technology guarantees no risk of arc leaking and ensures no fire or explosion
- Filled with gas (mostly hydrogen) to minimize contact oxidation and damage from arcing; the contact resistance is low and stable
- Contact part can meet IP67 protection level
- Current rated load continuously at 85°C
- Insulation resistance is 1000MΩ (1000VDC),and dielectric strength between the coil and contacts is 4.0kV ,which meets the requirements of IEC 60664-1

## APPLICATION

Energy storage system  
 Construction machinery  
 Charging pile  
 Solar inverter

## CONTACT DATA

Main Contact Arrangement	1 Form A
Initial Contact Voltage Drop	≤60mV at 250 A
Rated Current (resistive load)	250 A (@ 2x80mm <sup>2</sup> )
Rated Switching Voltage	1000VDC
Min.Applicable Load	6VDC, 1 A
Max. Switching Power (1000VDC)	250kW
Max. Breaking Current	2000A (1000VDC)
Aux. Contact Arrangement	1 Form A
Rated Load of Aux.	6VDC, 0.1A
Max Load of Aux.	5VDC, 1mA

## COIL DATA @ 23°C

Nominal Voltage (VDC)	Coil Power (W)	Nominal Current (A)	Coil Resistance (Ω±10%)	Pick-up Voltage (VDC)	Drop-out Voltage (VDC)
12	6	0.50	24	9.0 Max.	1 Min.
24	6	0.25	96	18.0 Max.	2 Min.

## ENDURANCE

Electrical Life (resistive Load)	Breaking: 30000 ops (50VDC,250A)
	Breaking: 1000 ops (1000 VDC,250A)
	Breaking: 1 op (1000 VDC,2000A)
Current Enduranc	250A, Cont.
	350A, 8 min
	1000A, 20s
	2000A, 1s
Mechanical endurance	5x10 <sup>5</sup> times, on-off ratio: 0.5s: 0.5s

## CHARACTERISTICS

Operate Time(at nominal voltage)		≤30ms
Release Time(at nominal voltage)		≤10ms
Insulation Resistance		> 1000 MΩ (at 1000 VDC)
Dielectric Strength	Between Coil and Contacts	4,000 VAC, 50/60 Hz (1min)
	Between Open Contacts	4,000 VAC, 50/60 Hz (1min)
Vibration		10Hz ~ 500Hz, 49 m/s <sup>2</sup>
Shock Resistance	Functional	196 m/s <sup>2</sup>
	Destructive	490 m/s <sup>2</sup>
Ambient temperature		-40°C ~ 85°C
Humidity		5%RH to 85%RH
Weight		Approx 450g

## ORDERING INFORMATION

Company Code 公司代号	CH	EV	H	250	/E	12	C	A	1	A	C	, XXX
Application Area 应用领域&类型	EV: New Energy Vehicles											
Series Code 系列代号	H: H Series											
Load Current 负载电流	250: 250A											
Load Voltage 负载电压	E:1000VDC											
Coil Specification 线圈规格	12: 12VDC; 24: 24VDC											
Coil Termination 线圈引出端形式	C: 连接器 Connector											
Contact Type 触点形式	A: Form A											
Load Termination 负载引出端形式	1:内螺纹Screw Terminal Female											
Aux. Contact Type 辅助触点形式	A: Form A											
Aux. Contact Termination 辅助触点引出形式	C: 连接器Connector											
Characteristic Code 特性号	Blank or Other Customer Requirements											

## OUTLINE DIMENSION

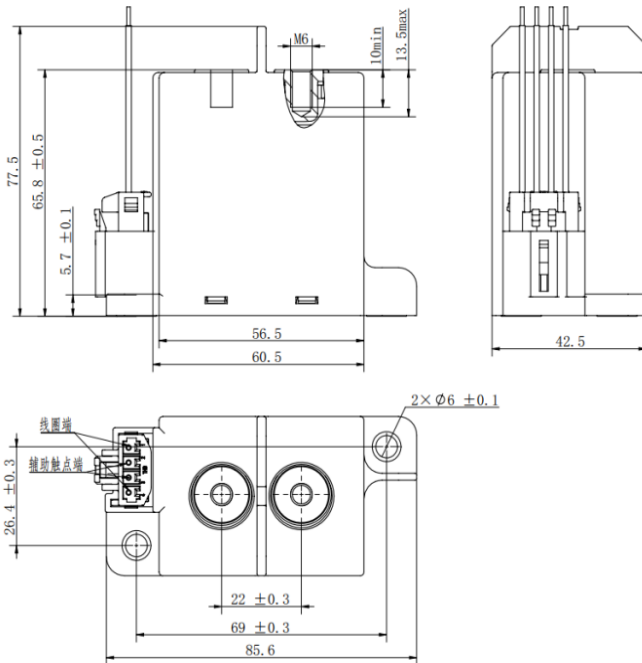

## WIRING DIAGRAM

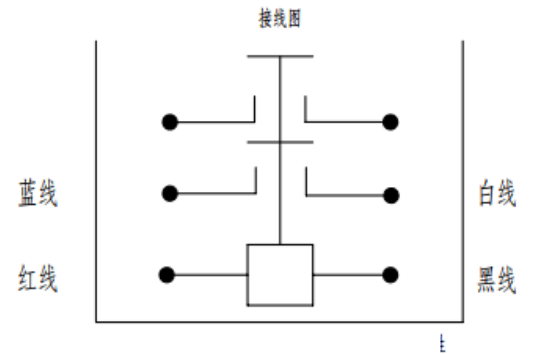

Note: The coil has no polarity, The load and Aux. have no polarity

Note: All unspecified tolerance according to following table.

Outline dimensions hadn't specified tolerance	
Outline Dimensions	Tolerance
≤ 10	±0.3
10 ~ 50	±0.6
> 50	±1

## COIL TERMINATION:CONNECTOR

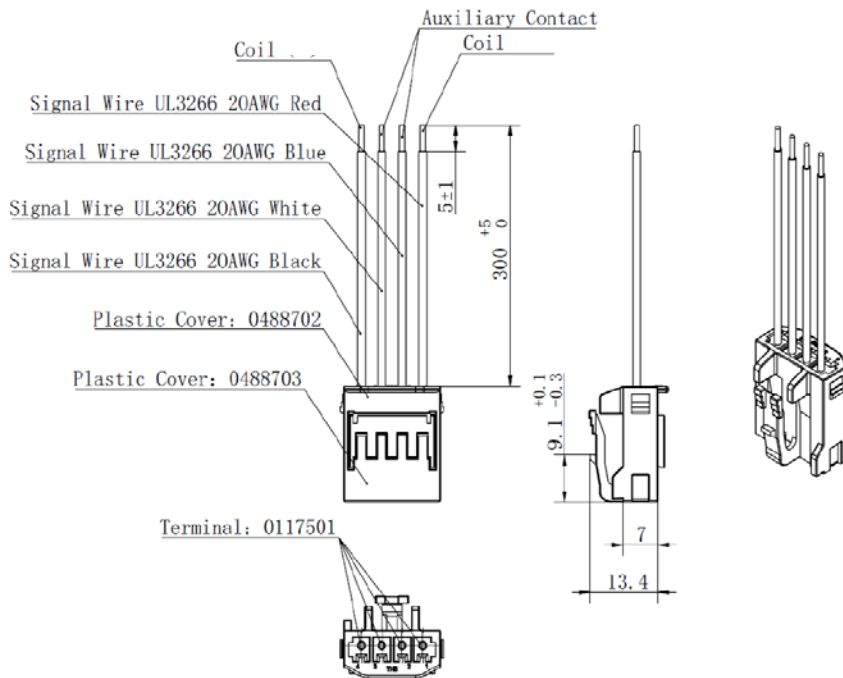

## INSTALLATION INFORMATION

Load Terminal Installation				
Installation Mode	Selection Screw	Torque	Copper Busbar Diameter	Copper Busbar Thickness
M6 Screw	M6 Combined Bolt	6 N·m ~8 N·m	Ø 6.0 mm~Ø 6.5 mm	2.0mm~3.0 mm

Relay Installation		
Mounting Type	Horizontal or vertical direction	Mounting Hole Size
Installation Mode	M5 Screw	
Torque	3N·m ~5N·m	

## ENGINEERING NOTES

1. Unless otherwise explicitly stated, the standard environment conditions for measurement or testing are listed as followings:

Ambient temperature is 23°C±5°C.

Atmospheric pressure is 96× (1±10%) kPa.

Relative humidity is 25% RH ~ 75% RH.

2. In order to curb the reverse electromotive force of coil, a nonlinear resistor is recommended to use (ZNR is recommended, the max energy tolerance:≥1J. Voltage: 1.5~2 times the rated voltage) . Please be noted that a diode will make the release time of relay increase, which should lead to the degradation of cutting-off capability. Relay products with circuit board do not need to add a device to curb the reverse electromotive force of the coil.

3. The rating load of contact is resistive load. Please assure a surge absorption device together with inductive load when using the L/R≥1ms inductive load (L Load), otherwise it may lead to the decrease of electrical endurance and defective switch.